

## Instruction manual

Installation – Operation – Maintenance – Inspection

## ZIMM Screw Jacks

**Z-5 to Z-1000**  
**GSZ-2 to GSZ-100**

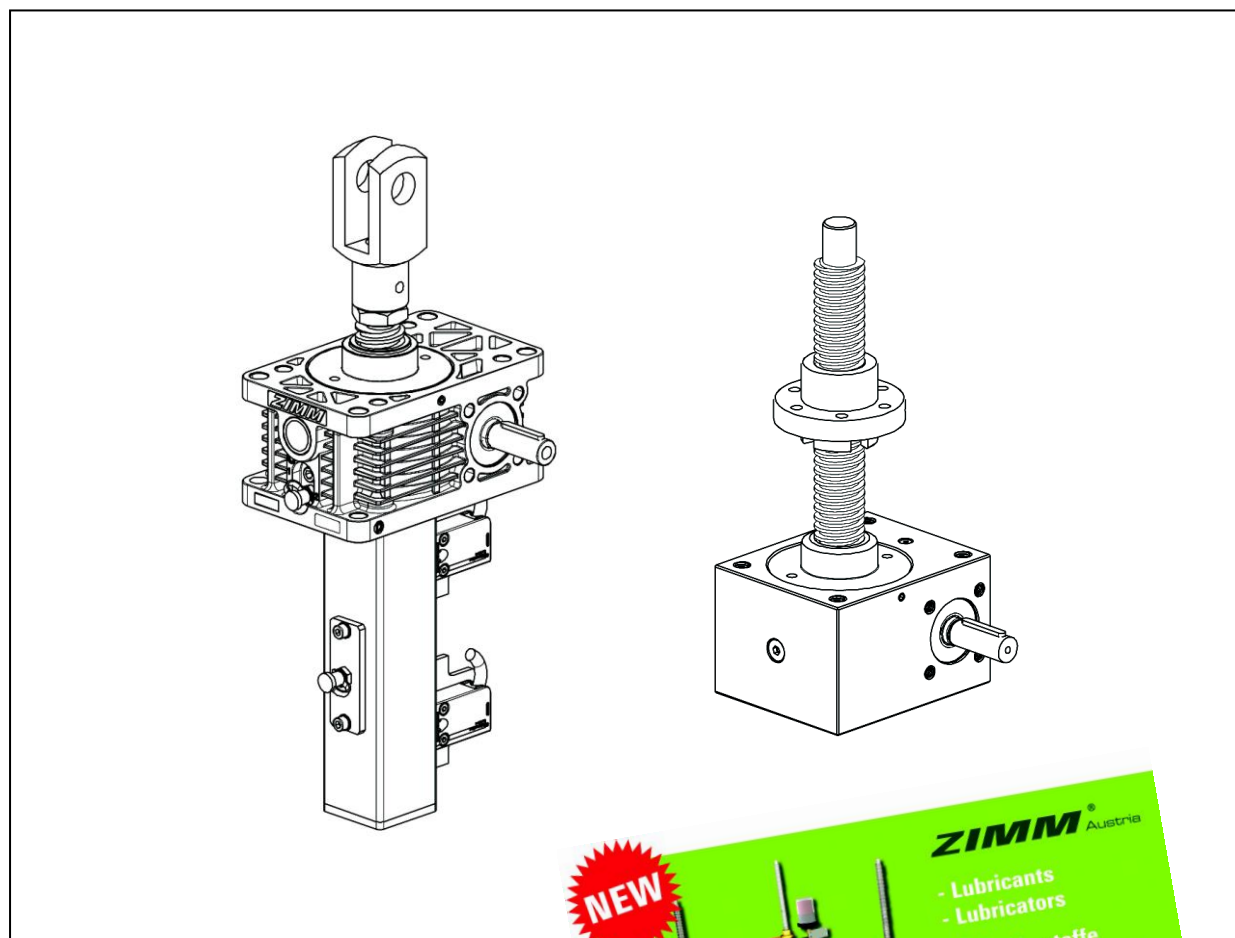

## **Translation of the original instruction manual**

### **Publisher**

ZIMM Maschinenelemente GmbH + Co KG  
Millennium Park 3  
6890 Lustenau/Austria

Tel.: 0043 (0) 5577 806-0

Fax: 0043 (0) 5577 806-8

e-mail: [info@zimm.at](mailto:info@zimm.at)

Internet: <http://www.zimm.eu>

### **Author**

ZIMM Maschinenelemente GmbH + Co KG

### **Issue date**

2015-01

### **Version**

1.2

### **Copyright**

© 2015 ZIMM Maschinenelemente GmbH + Co KG

We reserve the right to make changes to technical aspects and content

### **Legal notices**

The contents of this instruction manual must be kept confidential. It is intended only for use by company personnel.

Reproduction or distribution and release of this instruction manual to third parties is prohibited. Offenders are liable to pay damages.

The ZIMM Maschinenelemente GmbH + Co KG accepts no liability for damages arising from disregard of this instruction manual.

---

## Contents

<b>1</b>	<b>About this document</b> .....	<b>5</b>
1.1	Use of this instruction manual .....	5
1.2	Symbols and identifying marks .....	5
<b>2</b>	<b>Safety</b> .....	<b>6</b>
2.1	Use for the intended purpose .....	6
2.2	Duties of the operating company .....	6
<b>3</b>	<b>Scope of supply</b> .....	<b>7</b>
<b>4</b>	<b>Description of the product</b> .....	<b>7</b>
4.1	Overview .....	7
4.2	Rating plate .....	8
4.3	Versions/variants .....	9
4.4	Grease nipple .....	10
<b>5</b>	<b>Transport and storage</b> .....	<b>11</b>
5.1	Transport .....	11
5.2	Storage .....	13
<b>6</b>	<b>Installation</b> .....	<b>14</b>
6.1	Installing screw jacks and bevel gear drives .....	15
6.2	Fitting the couplings and connecting shafts .....	16
6.3	Fitting the motor .....	18
6.4	Connecting the electrical components .....	19
6.5	Trial running .....	21
6.6	Correcting the alignment .....	22
6.7	Commissioning .....	23
6.8	Running-in phase .....	23
<b>7</b>	<b>Operation and maintenance</b> .....	<b>24</b>
7.1	Inspection .....	24
7.2	Lubrication .....	25
7.3	Troubleshooting .....	31
<b>8</b>	<b>Decommissioning and recommissioning</b> .....	<b>33</b>
<b>9</b>	<b>Repair and replacement</b> .....	<b>33</b>
<b>10</b>	<b>Disposal</b> .....	<b>33</b>
<b>11</b>	<b>Declaration of incorporation</b> .....	<b>34</b>

---

12 Appendix: Inspection certificate.....35





# 1 About this document

## 1.1 Use of this instruction manual

This instruction manual forms part of the ZIMM Screw Jack.

- ➔ Before using the equipment read the instruction manual carefully.
- ➔ Keep the instruction manual safe throughout the working life of the equipment.
- ➔ Keep the instruction manual available to operating and maintenance personnel at all times.
- ➔ Pass the instruction manual to any subsequent owner or user of the equipment.
- ➔ Keep the instruction manual updated with any supplements issued by the manufacturer.

## 1.2 Symbols and identifying marks

Symbol	Meaning
 <b>DANGER</b>	Hazards to personnel Disregard will lead to death or serious injuries.
 <b>WARNING</b>	Hazards to personnel Disregard may lead to death or serious injuries.
 <b>CAUTION</b>	Hazards to personnel Disregard may lead to minor injuries.
<b>CAUTION</b>	Information for avoiding damage to property
 <b>NOTE</b>	Notes for understanding or optimising working procedures
✓	Precondition to an operation
➔	Single step operation requirement
1. ... 2. ...	Multi-step operation requirement ➔ Comply with the sequence

Tab. 1: Symbols and identifying marks

## 2 Safety

The ZIMM Screw Jack has been produced to modern standards and recognised safety regulations. Nevertheless hazards to life and limb of the users or third parties, or risks of damage to the ZIMM Screw Jack and other property may arise during use.

- ➔ The ZIMM Screw Jack may be used only when it is in technically good condition and in compliance with the instruction manual.
- ➔ Have any defects rectified without delay.
- ➔ Do not perform any unauthorised modifications to the ZIMM Screw Jack.
- ➔ Fit only original spare parts from ZIMM Maschinenelemente GmbH + Co KG.

### 2.1 Use for the intended purpose

The ZIMM Screw Jack is suitable only for lifting, lowering, tilting and advancing movements within the specified lifting capacity ranges. Responsibility to ensure correct use lies with the user.

Screw jacks may be used only in the context and within the limits specified in our catalogues and brochures.

To ensure compliance with the statutory limits for electromagnetic compatibility, the ZIMM Screw Jack may be used only within industrial applications as defined in EN 50 081-2.

Use for any purpose other than these intended purposes constitutes improper use.

If in doubt regarding the application of the ZIMM Screw Jack, consult ZIMM Maschinenelemente GmbH + Co KG before proceeding.

### 2.2 Duties of the operating company

- ➔ Ensure that the ZIMM Screw Jack is operated and maintained only in compliance with this instruction manual and the rules and regulations applicable in the country of use.
- ➔ Ensure that the personnel
  - responsible for operating the ZIMM Screw Jack are authorised,
  - are trained and qualified for the respective work,
  - have read and understood this instruction manual,
  - know the applicable safety rules and
  - wear personal safety equipment (safety gloves, safety helmet and safety shoes).

### 3 Scope of supply

The ZIMM Screw Jack is delivered in sufficiently secure packaging to prevent possible damage in transit.

The scope of supply of the ZIMM Screw Jack includes the following parts:

- ZIMM Screw Jack
- This instruction manual
- Further parts as listed on the delivery note

### 4 Description of the product

#### 4.1 Overview

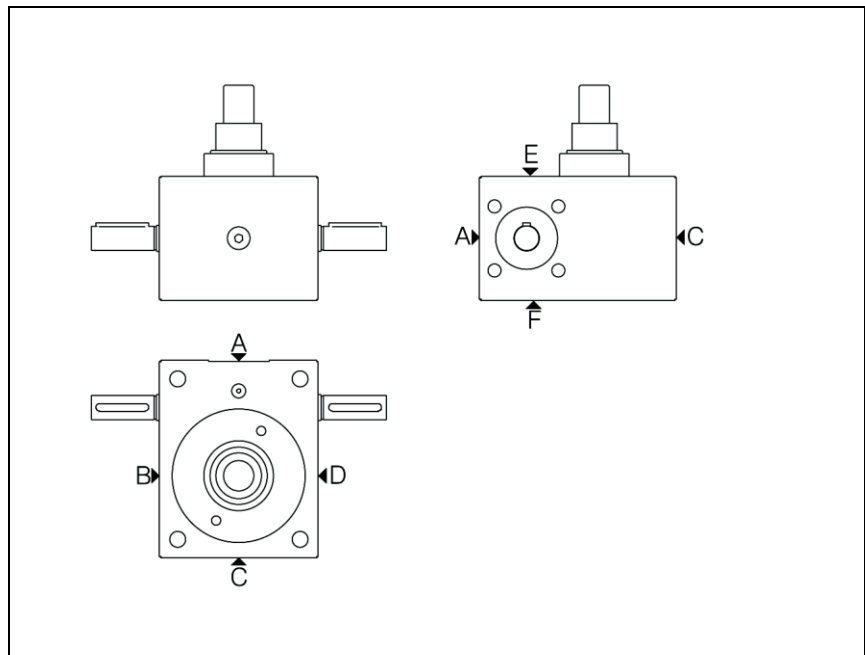

Fig. 1: Overview ZIMM Screw Jack

A to F: Faces of the ZIMM Screw Jack. For the Z series this is also displayed on the casing.

## 4.2 Rating plate

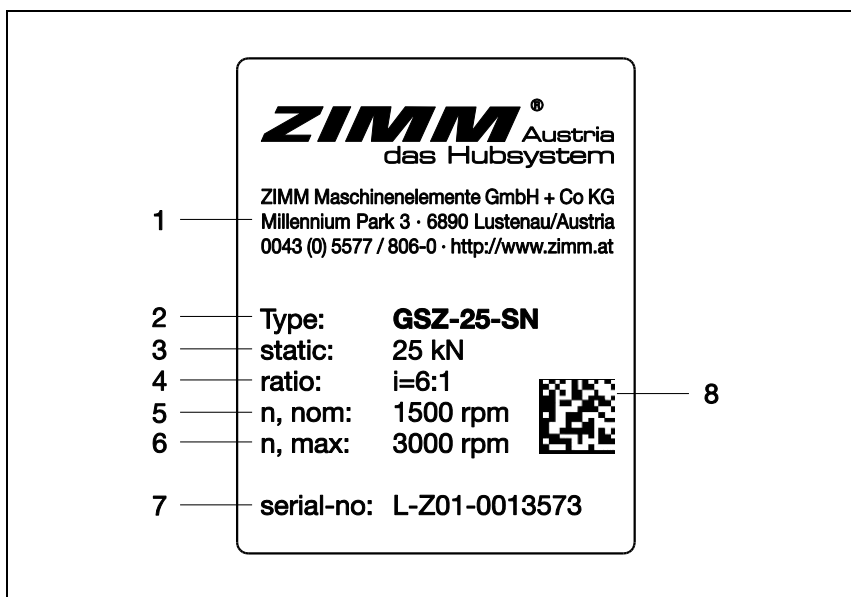
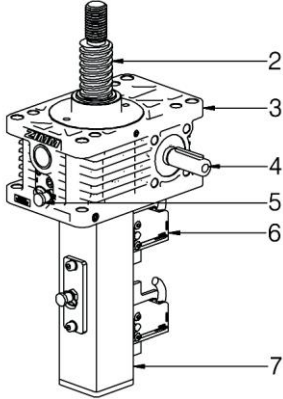
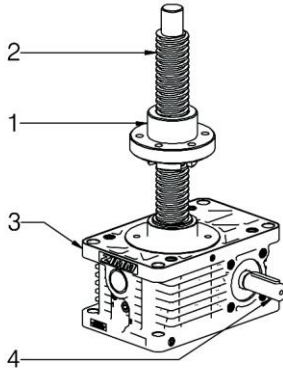
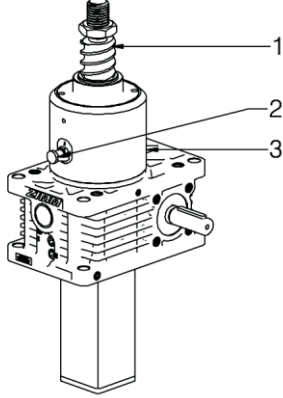
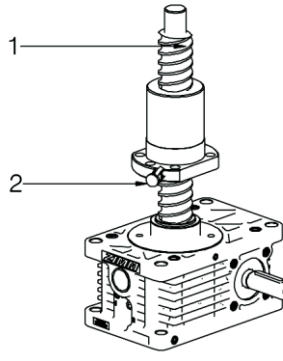

Fig. 2: Example of a rating plate

1	ZIMM contact data	5	Rated speed
2	Type designation	6	max. speed
3	Maximum static load gearbox (spindle etc. not considered)	7	Serial number
4	Gear ratio	8	Serial number as Data Matrix Code



### 4.3 Versions/variants

Variant	Static (S version)	Rotating (R version)
<p>Z series, Standard (with trapezoidal screw drive TR)</p>		
	<p>1 Travelling nut 2 Trapezoidal screw spindle TR 3 Housing, Z series 4 Drive shaft</p>	<p>5 Spindle lubrication 6 Limit switch 7 Protective tube</p>
<p>Z series, with ball screw drive KGT</p>		
	<p>1 Ball screw spindle KGT 2 Spindle lubrication</p>	<p>3 Gearbox for ball screw drive KGT</p>

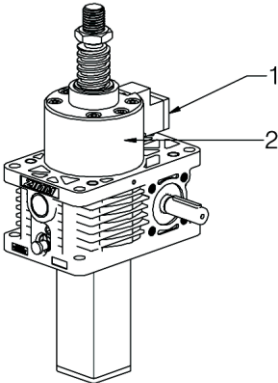
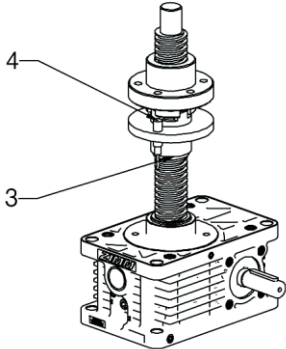
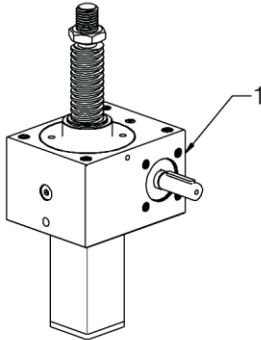
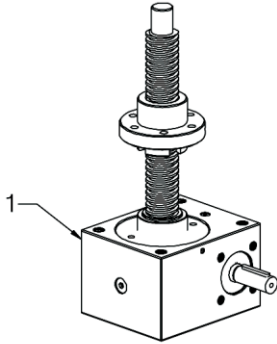
Variant	Static (S version)	Rotating (R version)
Z series, with safety nut SIFA		
	<p>1 Electrical or optical monitoring</p> <p>2 Gearbox with integral safety nut SIFA</p>	<p>3 Safety nut SIFA</p> <p>4 Electrical monitoring</p>
GSZ series, Standard		
	<p>1 Housing, GSZ series</p>	

#### 4.4 Grease nipple

S and R versions of the ZIMM Screw Jack are fitted with grease nipples, which allow simple and clean greasing of the spindle (apart from the flanged nut FM).

**!** **NOTE**

➔ For optimum greasing, use an automatic grease dispenser (such as the Z-LUB).

## 5 Transport and storage

### 5.1 Transport

#### WARNING

##### **Falling load!**

Falling loads may lead to serious injuries.

- Make sure that the lifting slings that are used are securely attached and cannot slip.
- Do not remain under a suspended load.
- Wear personal safety equipment.

#### CAUTION

##### **Heavy weight!**

Injuries from parts weighing 25 kg and above.

- Transport the heavy ZIMM Screw Jack correctly (max. 25 kg per person).

#### CAUTION

##### **Damage to the ZIMM Screw Jack!**

- On receipt, check the packaging for signs of damage.
- Do not let the ZIMM Screw Jack drop, and do not subject it to impacts.
- Use appropriate lifting gear as necessary.

##### **Risk of bending the spindle!**

- Take particular care when handling long and slender spindles, so as to avoid bending them.

**S version**

Fig. 3: Examples for transporting the S version

- ➔ When lifting with a crane, attach the slings to the lifting points provided.
- ➔ When lifting the ZIMM Screw Jack for transport, spread the weight as evenly as possible across all the lifting points.

**R version**

Fig. 4: Examples for transporting the R version

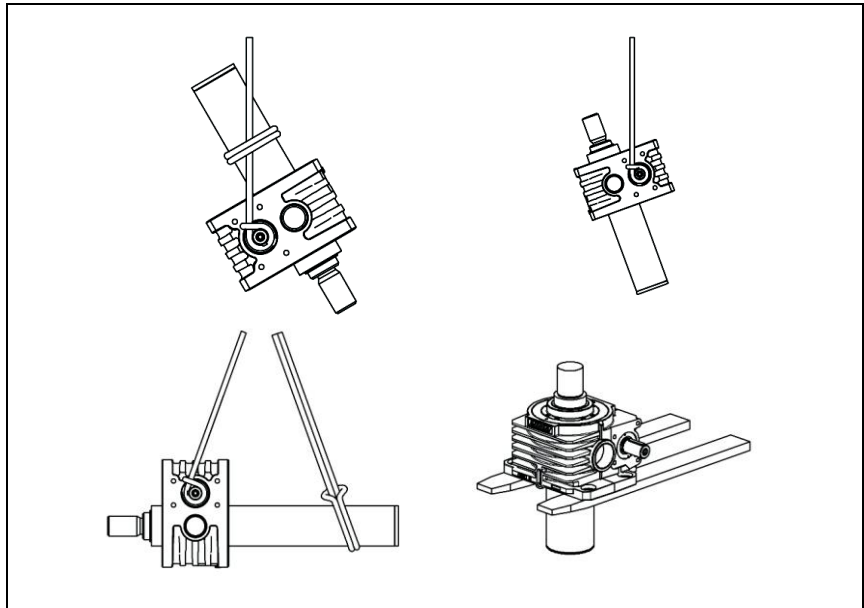
**Securing for transport**

For secure attachment, insert ring bolts or ring nuts to the gearbox.

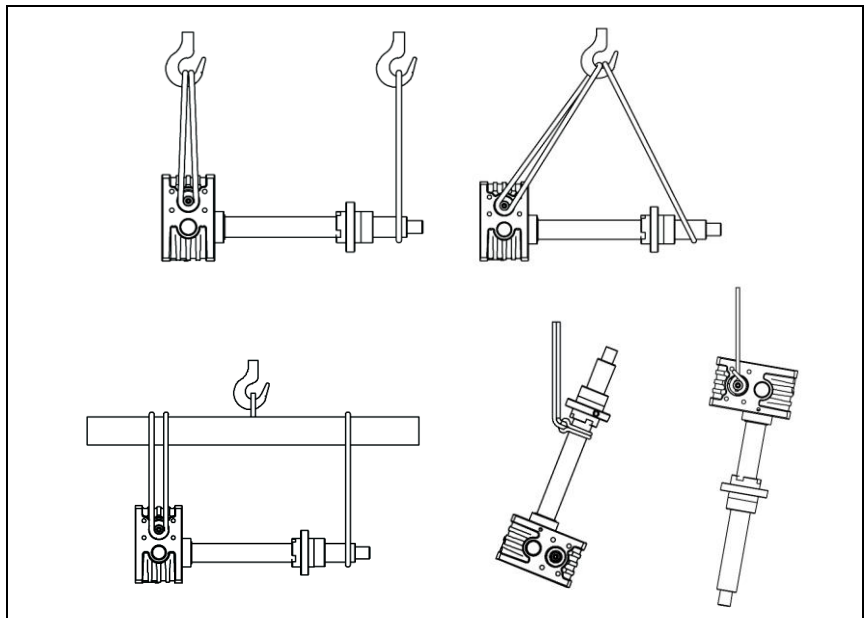
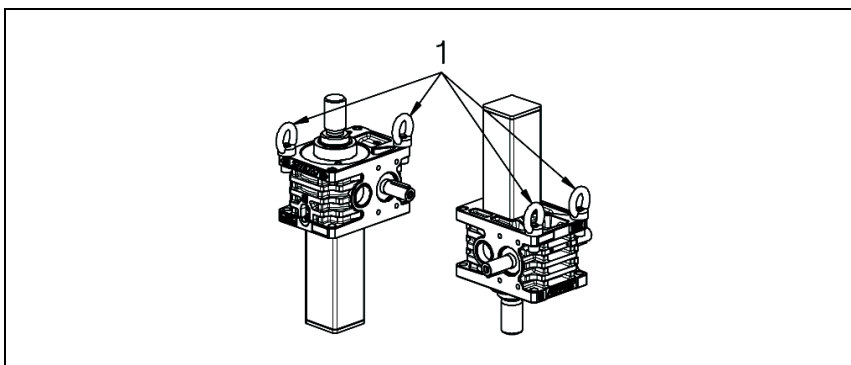

Fig. 5: Fit ring bolts (1) or ring nuts (not supplied)

**5.2 Storage****CAUTION****Incorrect storage!**

Damage due to corrosion.

- ➔ Store only in enclosed and dry rooms.
- ➔ Do not store for more than a brief period in areas that although roofed still allow free circulation of air from outside.
- ➔ Perform commissioning not later than 1 year after delivery (the dispatch from ZIMM is the relevant date).

- ➔ For other storage conditions and storage times:  
Consult ZIMM Maschinenelemente GmbH + Co KG.

## 6 Installation

### CAUTION

#### Laceration, trapping and crushing hazards!

- ➔ Switch off the entire system and secure it against switching on again.
- ➔ Allow only skilled and trained personnel to perform the work.
- ➔ Do not remove the covers that are fitted.
- ➔ Wear personal safety equipment.

#### Sharp edges!

Laceration hazard.

- ➔ Wear safety gloves.

### CAUTION

#### High forces are generated!

Material damage to the entire system and the screw jack.

- ➔ Ensure that the following installation conditions are satisfied:
  - Limit switches are not overrun.
  - For parallelism and angularity tolerances: see section 6.1, page 15.
  - Directions of rotation and movement are correct for all components.
  - Safety clearance between moving and fixed parts is maintained.

#### Lack of self-locking!

Material damage to the entire system and the screw jack due to lack of self-locking for spindles with ball screw drive KGT.

- ➔ Spring pressure brake FDB or brake motor provided.
- ➔ For the S version run-off protection AS or torsional protection VS is provided.
- ➔ In particular for vertical installation, make sure that during installation neither the spindle nor the nut unscrews.

**CAUTION**

**The system will run on!**

Material damage to the entire system and the screw jack due to running on.

- The run-on travel may increase after the running-in phase.
- ➔ If necessary provide a spring pressure brake FDB or brake motor.

**NOTE**

Additional hazards may arise during installation and operation of the overall system.

- ➔ Comply with regional regulations and take necessary measures (such as risk assessment).
- ➔ Document all additional hazards in the documentation for the overall system.

**6.1 Installing screw jacks and bevel gear drives**

- ✓ Ensure that the spindle of the ZIMM Screw Jack or on the ZIMM Screw Jack cannot be exposed to lateral loads.

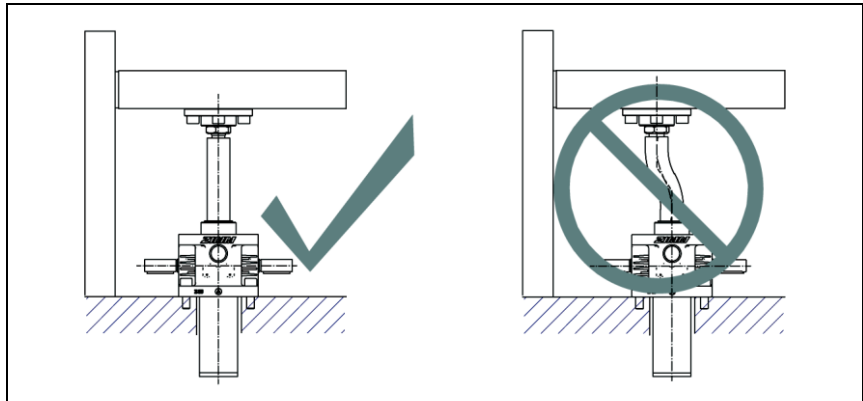

Fig. 6: Side forces on the spindle are not permissible.

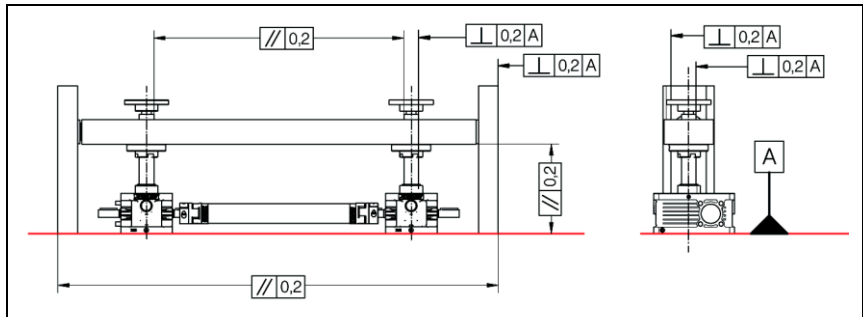

Fig. 7: Flatness, parallelism and angular accuracy

1. Install the ZIMM Screw Jack and ensure straight alignment for the spindle attachments.
2. Install the ZIMM Screw Jack with bolts, tighten the installation bolts.
3. Install the spindle attachment with bolts, tighten the installation bolts.

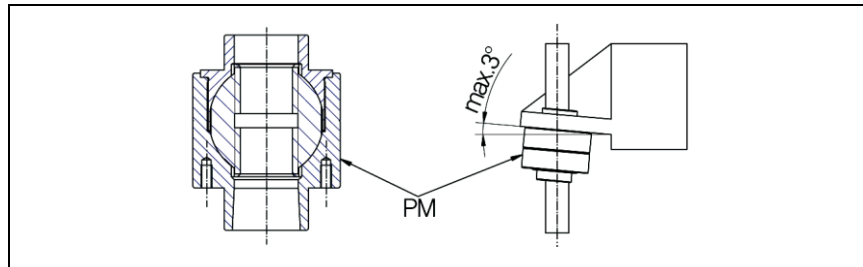

Fig. 8: Exceptions: Maximum inclination angle for self-aligning nuts (PM) is 3°, install all other nuts at right angles.

### Bevel gear drive

The T version can be turned round to change the direction of rotation.

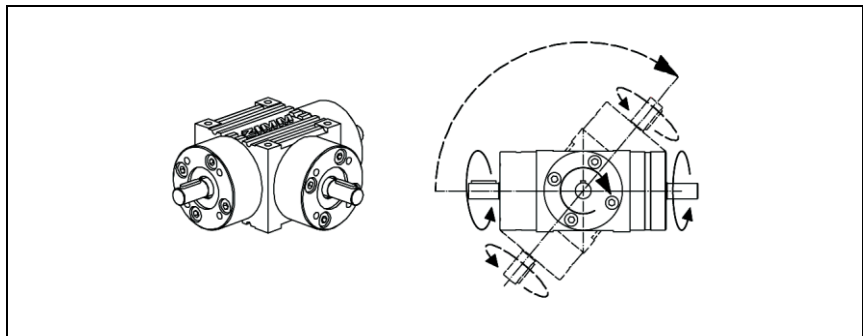

Fig. 9: T version (bevel gear drive)

➔ Check the direction of rotation at installation.

## 6.2 Fitting the couplings and connecting shafts

- ✓ The screw jacks to be connected must have been fully installed.
- ✓ The bevel gear drives must be installed where appropriate.

### **⚠ CAUTION**

#### **Moving parts!**

Injuries due to rotating parts.

- ➔ Switch off the entire system and secure it against switching on again.

1. Place the connecting shaft on the shaft extensions (ZIMM Screw Jack or bevel gear drives). Check that the gearboxes are correctly levelled.



- Secure the coupling half shells with attachment bolts tightened to the following torques:

Connecting shaft	Coupling	Torque
VWZ-30	KUZ-KK-16	4 Nm
VWZ-40	KUZ-KK-24	8 Nm
VWZ-60	KUZ-KK-32	15 Nm
VWZ-60V	KUZ-KK-35	35 Nm
VWZ-80	KUZ-KK-45	70 Nm
VWZ-100	KUZ-KK-60	120 Nm

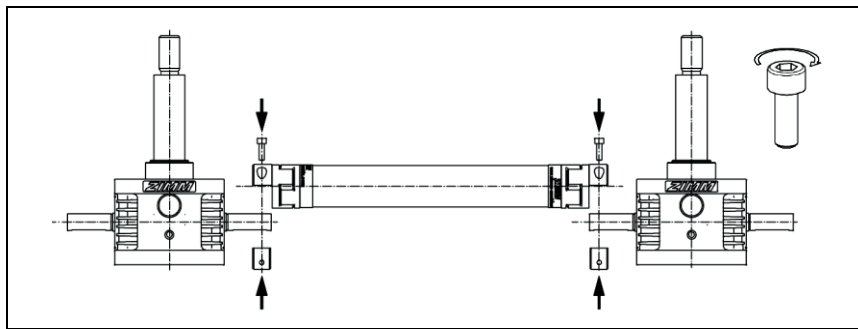

Fig. 10: Installation of connecting shafts

**CAUTION**

**Axial joining force!**

Damage to the roller bearings, circlips etc.

- ➔ Use a suitable fixture to draw the connecting parts together.
- ➔ Do not apply blows or impacts to the shaft extensions.

Pull the couplings KUZ (couplings without half shells) on to the shaft extensions. Tighten the set screw to the following torques:

Size KUZ-..	Set screw	Torque
09, (14)	M4	1.5 Nm
24, 28	M5	2.0 Nm
14, 19, 38	M6	4.8 Nm
45, 55, 60	M8	10 Nm
70, 75, 90	M10	17 Nm

For increased security the set screw can be secured using “medium strength” thread locking agent.

### 6.3 Fitting the motor

- ✓ The screw jack must be installed.

#### **⚠ CAUTION**

##### **Moving parts!**

Injuries due to rotating parts.

- ➔ Switch off the entire system and secure it against switching on again.

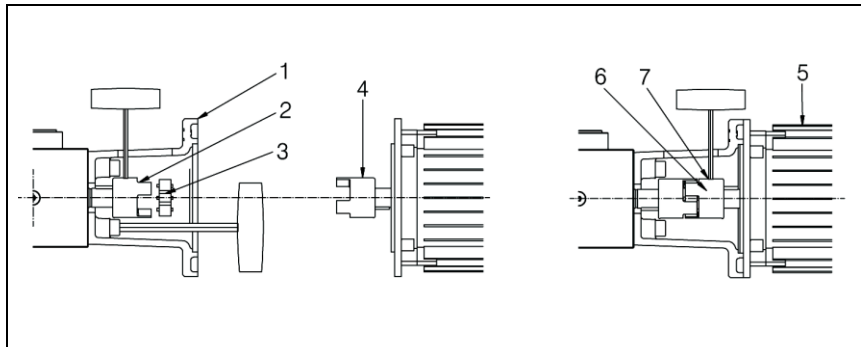

Fig. 11: Installing the motor

1. Fit the motor flange (1) to the screw jack and bolt it into place.
2. Fit the coupling halves (2) to the gearbox shaft and bolt them into place.
3. Attach the coupling star (3).
4. Pull the motor-side coupling halves (4) on to the motor shaft.
5. Attach the motor (5) to the motor flange and bolt it into place.
6. Fit the motor-side coupling halves (6) as follows:
  - Slide them on to the gearbox-side coupling halves, leaving 1 mm axial play.
  - Tighten the securing bolt (7).
  - If the coupling halves cannot be slid on to the motor shaft: Adjust the position before step 5 and tighten them.

## 6.4 Connecting the electrical components

### **⚠ WARNING**

#### **Electric shock!**

Electric shock can lead to death or serious injuries.

- ➔ Allow only skilled electricians to work on the electrics.
- ➔ Comply with the basic rules:
  - Deenergise the system.
  - Secure it against switching on again.
  - Ensure all phases are electrically dead.
  - Earth and short-circuit the system.
  - Cover any adjacent parts that are still live.

### 6.4.1 Motor

- ✓ The motor (if supplied) must be installed.
1. Open the motor terminal box. The connection assignment is shown within the motor terminal box.
  2. Connect the motor in accordance with the circuit diagram.

### 6.4.2 Limit switch

#### Connecting the limit switch

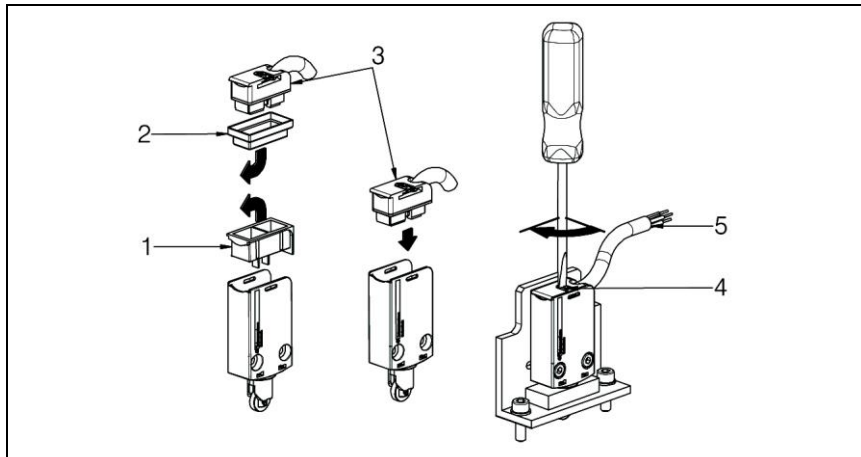

Fig. 12: Fitting the plug connector on the limit switch

1. Remove the protection element (1) from the limit switch.
2. Remove the protection element (2) from the plug connector.
3. Insert the plug connector (3) into the limit switch.
4. Turn the screw (4) 90° clockwise.

5. Connect the cable ends (5) in accordance with diagram (see Fig. 13).

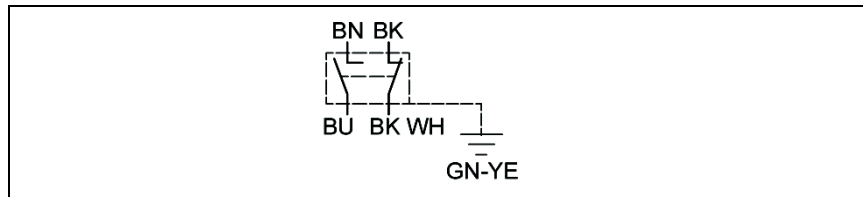

Fig. 13: Connection diagram for the limit switch

BN Brown  
BK Black

BU Blue

BK-WH Black-White  
GN-YE Green-Yellow

### Turning the cable outlet

If necessary the cable outlet can be turned through 180°.

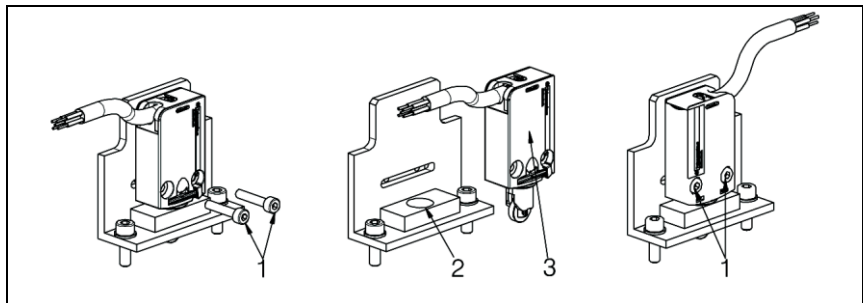

Fig. 14: Turning the cable outlet of the limit switch

1. Loosen the screws (1) and unscrew them.
2. Pull the limit switch (3) out of its bracket (2) and turn it through 180°.
3. Insert the limit switch into the bracket (2) again.
4. Refit the screws (1) and tighten them.

### Adjusting the position of the limit switch

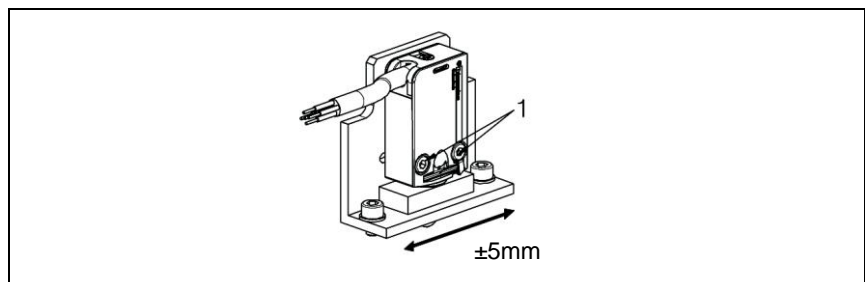

Fig. 15: Adjustment of the limit switch

1. Move the screw jack away from the limit switch trigger point.
2. Loosen the screws (1).
3. Adjust the limit switch by sliding it in the direction shown.
4. Tighten the screws (1).

## 6.5 Trial running

- ✓ The system must be installed and aligned.
- ✓ The spindle must be greased (for more information see section "7.2 Lubrication", page 25).

### CAUTION

#### Lateral forces due to incorrect alignment!

Damage to the gearbox and spindle.

1. If the alignment is defective: Correcting the alignment, see section 6.6, page 22.
2. Repeat the trial run.

#### High forces are generated!

Damage to the ZIMM Screw Jack.

- ➔ Make sure that the limit switch (optional) and end bearings are not overrun.
- ➔ Make sure that attachments do not collide with other parts.

- ➔ Run the screw jack over the complete travel in both directions. When doing this, comply with the following:
  - Run the screw jack slowly and carefully.
  - As far as possible, run it with no load or with only a small load.
  - Current consumption should be within the normal range, and should be constant.  
Major fluctuations indicate alignment errors and stresses.
  - Monitor the temperature and avoid overheating, especially where the travel is long and multiple runs are performed successively.
  - Avoid overrunning the limit switch (optional).

## 6.6 Correcting the alignment

If necessary, the alignment can be corrected without much trouble.

- ✓ The spindle must be greased (for more information see section "7.2 Lubrication", page 25).

### S version

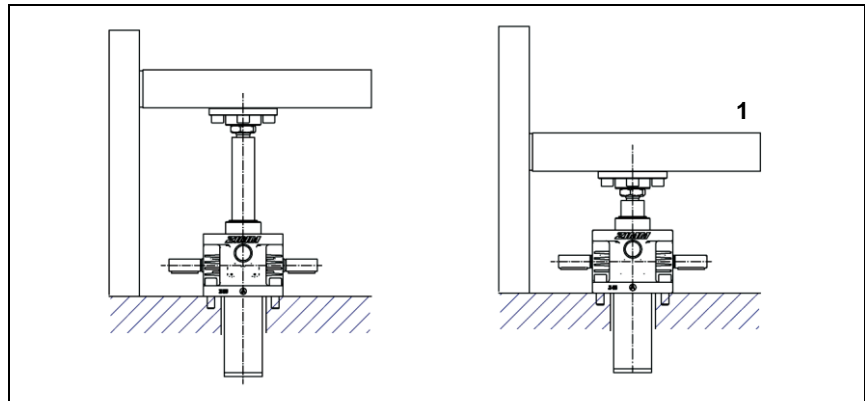

Fig. 16: Correctly aligned screw jack - S version

1. Slacken the securing bolts on the gearbox casing and at the end of the spindle.
2. Fully retract the jack (1).
3. Tighten the securing bolts.
4. Repeat the trial run (see section 6.5, page 21).

### R version

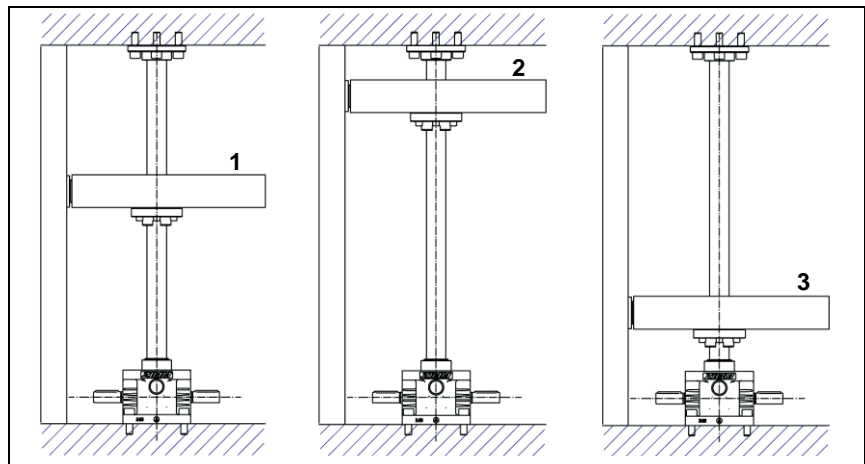

Fig. 17: Correctly aligned screw jack - R version

1. Move the nut to the middle (1).
2. Slacken the securing bolts on the gearbox casing and on the end bearing plate GLP.
3. Extend the nut to just before the end bearing plate (2).

4. Tighten the securing bolts on the end bearing plate.
5. Retract the nut to just before the gearbox (3).
6. Tighten the securing bolts on the gearbox casing.
7. Repeat the trial run (see section "6.5 Trial running", page 21).

## 6.7 Commissioning

- ✓ The ZIMM Screw Jack together with its attachments must be installed and connected.
- ✓ The spindle must be greased (for more information see section "7.2 Lubrication", page 25).
- ✓ The trial run must have been completed successfully.

### CAUTION

#### High forces are generated!

Damage to the ZIMM Screw Jack.

- ➔ Make sure that the limit switch (optional) and end bearings are not overrun.
- ➔ Make sure that attachments do not collide with other parts.

1. Check all screw fastenings once again.
2. Perform a trial run with operating load.  
When doing this, comply with the following:
  - Torque must be constant.
  - Current consumption must be constant.
  - Operating temperature must be within the normal range.
  - The limit switch (if fitted) or the end bearings must not be overrun.
3. Regrease the spindle after the first 2 operating hours at medium load.

## 6.8 Running-in phase

The running-in phase of the gearbox and spindle lasts as a rule between 20 and 50 operating hours. A higher torque and higher operating temperature must be expected during this period.

The torque may be up to 50% higher during the running-in phase than in subsequent operation.

## 7 Operation and maintenance

### WARNING

#### Lifting movements within the hazard zone!

Serious injuries or death.

➔ Leave the hazard zone and secure it.

### 7.1 Inspection

For problem-free operation, the ZIMM Screw Jack must be inspected regularly:

- The first inspection should be no later than after 1 month
  - Further inspections should be performed at least annually
1. Record the inspections, for a template see "Appendix: Inspection certificate", page 35.
  2. If necessary, perform Troubleshooting, see section 7.3, page 31.
- ➔ If problems cannot be localised and rectified:  
Contact ZIMM Maschinenelemente GmbH + Co KG.

#### 7.1.1 Visual check

- ✓ Switch off the machine and secure it against switching on again.
1. Check the greasing of the spindle, if necessary regrease and revise the maintenance interval.
  2. Check the screws for the attachments and couplings/connecting shafts and if necessary retighten them.
  3. If a safety nut SIFA is fitted: Check wear in accordance with the Fig. 18 (right hand picture) .
    - Make a note of dimension "A" and compare it with the set value.
    - Maximum permissible wear: 25% of the screw pitch.
    - If electronic monitoring is fitted, this check is not required.



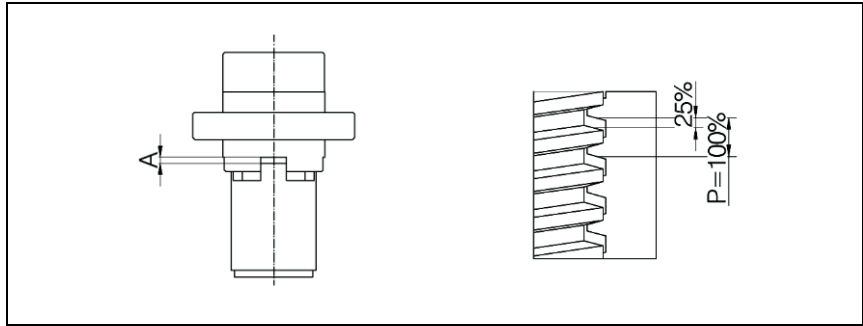

Fig. 18: Safety trap nut SIFA: Dimension "A" for comparison when checking wear

4. Visually check the coupling stars.
5. Allow the machine to run, checking for the following:
  - Running without jerking and vibration
  - No excessive noise
  - Constant current consumption
  - Temperature rise within the -permissible range

## 7.2 Lubrication

Good lubrication and use of the correct lubricants are critical for the correct operation and working life of the screw jack.

Each screw jack application has different requirements, therefore the values specified in the following section are only recommendations.

### NOTE

ZIMM standard greases are not hazardous substances.

→ Contact ZIMM for the safety data sheets.

### 7.2.1 Lubricating screw jacks

The Z and GSZ series ZIMM Screw Jack are sealed and are filled with high-quality synthetic low-viscosity grease; from size 250 kN they are filled with synthetic oil.

Under normal operating conditions the gearbox is lubricated for life.

### 7.2.2 Lubricating bevel gear drives

Bevel gear drives are filled with synthetic oil and under normal operating conditions lubricated for life.

### 7.2.3 Greasing the spindle of a trapezoidal screw jack TR)

#### Intervals

The spindle of a trapezoidal screw jack must be greased regularly as required.

Procedure	Interval
Regreasing the spindle	Every 500 double strokes
Clean the spindle and regrease it.	If the spindle is dirty
	Annually in normal operation.
	Every 2 years in clean conditions.

#### NOTE

The interval for greasing depends on the application.

→ Monitor the state of the grease, and specify the interval accordingly.

#### Greases



Standard grease up to size 150 kN:

Part no.: Castrol Tribol GR 4020/460-2 PD, 400 ml cartridge

Standard grease from size 250 kN:

Part no.: Castrol Tribol GR 3020/1000-2 PD, 400 ml cartridge

Quantities for greasing new trapezoidal screw spindles TR:

TR Ø (mm)	16	18	20	30	40	50	55	60	80	100	120	140	160
Quantity (ml/m)	24	27	30	45	60	75	83	90	120	150	180	210	240

#### NOTE

The quantity for regreasing is less.

→ When regreasing, use less grease.

**Preconditions**

- ✓ When changing the grease: The spindle must be clean.

### ⚠ WARNING

#### **Jack travel in the lifting travel zone!**

Death, serious injury or crush hazard.

- ➔ When using a grease gun for greasing, make sure that sufficient freedom of movement is available for the entire jack travel.
- ➔ If there is insufficient freedom of movement:
  - Switch off the entire system and secure it against switching on again.
  - Performing greasing when installed.
  - For greasing when installed: Grease successively in several positions, so that the spindle is evenly greased.

### CAUTION

#### **Unsuitable grease!**

Damage to the spindle.

- ➔ Do not use multi-purpose grease.
- ➔ Do not mix greases.
- ➔ When changing the grease: Clean the spindle then regrease it.
- ➔ If necessary use special grease.
- ➔ Use only greases that are approved by ZIMM Maschinenelemente GmbH + Co KG.
- ➔ ZIMM will be pleased to give advice.

1. Remove the protective cap from the grease nipple.
2. Press the nozzle of the grease gun against the grease nipple:
  - S version: Grease nipple on the gearbox casing
  - R version: Grease nipple on the travelling nut (optional)
3. Filling with grease:

**When extending**

- Providing personal safety is assured: Perform greasing when extending, in order to ensure the best distribution of the grease.
- To do this, slowly extend the screw jack and apply strokes of the grease gun. When doing so, make sure the correct quantity of grease is applied.

**When stationary**

- It is best to apply grease in several jack positions, to ensure good distribution of grease.
- S version: Apply only small quantities of grease at each jack position, so that grease is not forced through the seals into the gearbox.
- R version: If no grease nipple is fitted, apply the grease directly to the spindle.

**! NOTE**

Simple greasing during operation.

The automatic grease dispenser **Z-LUB** provides optimum distribution of the grease.

➔ Use the automatic grease dispenser **Z-LUB** instead of a grease gun.

➔ ZIMM will be pleased to give advice.

There are different greases for different applications.

- High temperature
- Low temperature
- Food processing industry
- Heavy-duty applications
- etc.

➔ ZIMM will be pleased to give advice.

### 7.2.4 Greasing the ball screw drive KGT spindle

**Intervals**

Procedure	Interval
Regreasing the spindle	If heavily loaded after 100 hours (effective)
	If normally or lightly loaded: after 300 hours (effective)
Clean the spindle and regrease it	If the spindle is dirty

 **NOTE**

The interval for greasing depends on the application.

- ➔ Monitor the state of the grease, and specify the interval accordingly.

**Grease**



Standard grease for ball screw drive KGT  
Part no.: Castrol Tribol GR 4747/220-2 HT, 400 ml cartridge

Quantity (indicative value):

- 1 ml per 1 cm spindle diameter.

**Preconditions**

- ✓ When changing the grease: The spindle must be clean.

 **WARNING**

**Jack travel in the lifting travel zone!**

Death, serious injury or crush hazard.

- ➔ When using a grease gun for greasing, make sure that sufficient freedom of movement is available for the entire jack travel.
- ➔ If the freedom of movement is insufficient
  - Switch off the entire system and secure it against switching on again.
  - Performing greasing when installed.
  - For greasing when installed, move the nut successively to several positions, so that the spindle is evenly greased.

**CAUTION****Unsuitable grease!**

Damage to the spindle.

- ➔ Do not use multi-purpose grease.
- ➔ Do not mix greases.
- ➔ When changing the grease: Clean the spindle then regrease it.
- ➔ If necessary use special grease.
- ➔ Use only greases that are approved by ZIMM Maschinenelemente GmbH + Co KG.
- ➔ ZIMM will be pleased to give advice.

1. Remove the protective cap from the grease nipple.
  2. Press the nozzle of the grease gun against the grease nipple:
    - S version: Grease nipple on the gearbox cover.
    - R version: Grease nipple on the travelling nut.
  3. Filling with grease:
    - Providing personal safety is assured: Perform greasing when extending, in order to ensure the best distribution of the grease.
    - To do this, slowly extend the screw jack and apply strokes of the grease gun. When doing so, make sure the correct quantity of grease is applied.
- When extending**
- It is best to apply grease in several jack positions, to ensure good distribution of grease.
  - S version: Apply only small quantities of grease at each jack position, so that the grease is not forced through the seals into the gearbox.
- When stationary**

**NOTE**

There are different greases for different applications.

- Clean room
- Vacuum
- Food processing industry
- etc.
- ➔ ZIMM will be pleased to give advice.

### 7.3 Troubleshooting

If faults are evident, these should be localised according to specific criteria, and rectified by application of appropriate actions. The following table offers start points as assistance for troubleshooting.

Fault	Possible cause	Action
Spindle squeaking or vibrating	incorrect spindle grease, Stick slip	<ul style="list-style-type: none"> <li>➔ Use a different grease:               <ul style="list-style-type: none"> <li>– with a high-viscosity base oil</li> <li>– with additives</li> <li>– maybe containing solid lubricants</li> </ul> </li> <li>➔ ZIMM will be pleased to give advice.</li> </ul>
	Geometry errors in the system	<ul style="list-style-type: none"> <li>➔ Check the alignment:               <ul style="list-style-type: none"> <li>– Parallelism of the spindles to each other</li> <li>– Parallelism of the spindles to the guides</li> <li>– angular alignment of the mating faces (gearbox, nut, flange, etc.)</li> </ul> </li> </ul>
	Long slender spindle	<ul style="list-style-type: none"> <li>➔ Where possible, provide additional supports or bearings for the spindle.</li> <li>➔ Reinforce the design.</li> </ul>
	Temperature of the spindle too high (> approx. 90 °C)	<ol style="list-style-type: none"> <li>1. Check the operating parameters.</li> <li>2. Reduce the duty cycle or load.</li> </ol> <ul style="list-style-type: none"> <li>➔ ZIMM will be pleased to give advice.</li> </ul>
	Resonant spindle frequency	<ul style="list-style-type: none"> <li>➔ Change the speed: faster or slower (within the limit values).</li> </ul>
	Excessive load	<ul style="list-style-type: none"> <li>➔ Reduce the load during the running-in phase.</li> </ul>
	Vibrations transferred from the system	<ul style="list-style-type: none"> <li>➔ Install plastic or rubber pads under the travelling nut (for the R version).</li> </ul>
	High wear on the trapezoidal screw	The spindle is dirty
Wrong spindle grease		<ol style="list-style-type: none"> <li>1. Check the spindle grease, ZIMM will be pleased to give advice (load, speed, etc.).</li> <li>2. If necessary clean the spindle and regrease it.</li> </ol>
Lack of grease		<ol style="list-style-type: none"> <li>1. If necessary clean the spindle and regrease it.</li> <li>2. Shorten the greasing intervals.</li> </ol>

Fault	Possible cause	Action
	Geometry errors in the system	→ Check the alignment: <ul style="list-style-type: none"> <li>– parallelism of the spindles to each other</li> <li>– parallelism of the spindles to the guides</li> <li>– angular alignment of the mating faces (gearbox, nut, flange, etc.)</li> </ul>
	Load too high	→ Contact ZIMM (load, speed, duty cycle, etc.).
Operating temperature too high	Load or duty cycle too high	→ Check the operating parameters, ZIMM will be pleased to give advice.
	Geometry errors in the system	→ Check the alignment: <ul style="list-style-type: none"> <li>– parallelism of the spindles to each other</li> <li>– parallelism of the spindles to the guides</li> <li>– angular alignment of the mating faces (gearbox, nut, flange, etc.)</li> </ul>
	Wrong spindle grease	1. Check the spindle grease, ZIMM will be pleased to give advice (load, speed, etc.). 2. Clean the spindle and regrease it.
Noise at the coupling or connecting shaft	Rubbing at the coupling star	→ Grease the coupling star with Vaseline or plastic-compatible grease.
	Permissible offset exceeded	→ Check the alignment and correct it as necessary.
Slight leakage at the shaft sealing ring	Slight leakage	Some slight leakage is normal and not a technical problem. → Wipe off the leakage and keep monitoring it.
Heavy leakage	Shaft sealing ring defective or excessive pressure in the gearbox.	→ Contact ZIMM and send photos.



## 8 Decommissioning and recommissioning

### Decommissioning

#### CAUTION

##### Corrosion!

Damage to the screw jack after a long period out of use.

→ Oil bright metal surfaces and grease the spindle.

### Recommissioning

After the ZIMM Screw Jack has been out of use for a long period:

1. Clean the spindle and
2. Regrease the spindle, see section "7.2 Lubrication", page 25.

## 9 Repair and replacement

#### NOTE

The warranty becomes void if the ZIMM Screw Jack is dismantled.

→ Allow the ZIMM Screw Jack to be dismantled only by ZIMM or by personnel authorised by ZIMM.

→ Contact ZIMM Maschinenelemente GmbH + Co KG.

## 10 Disposal

The ZIMM Screw Jack satisfies the current standards and regulations for disposal of end of life equipment. It contains no poisonous substances which demand the taking of special precautions.

→ During disposal, ensure:

- Compliance with regional laws and regulations for waste disposal
- Correct disposal and recycling should be entrusted to a professional disposal company

The following materials will require disposal:

- Lubricants (grease or oil in the gearbox, lubricating grease on the spindle)
- Steel parts (coated with environmentally-friendly paints or coatings)
- Anodised aluminium (parts)
- Bronze/copper (bevel gear, nuts or windings on the motor)
- Plastic parts (seals etc.)

# 11 Declaration of incorporation

**ZIMM Maschinenelemente GmbH + Co KG**  
 Millennium Park 3 | 6890 Lustenau/Austria  
 Tel: +43 (0) 5577/806-0 | Fax: +43 (0) 5577/806-8  
 E-Mail: info@zimm.at | http://www.zimm.at

**ZIMM**<sup>®</sup> Austria  
 das Hubsystem

## Declaration of incorporation for partly completed machinery (Described in EC Machinery Directive 2006/42/EC, Annex II B)

The manufacturer "ZIMM Maschinenelemente GmbH + Co. KG" declares herewith that all "screw jacks" delivered by ZIMM of the models SHZ, MSZ, Z or GSZ

**Size (max. load)**

02 (0,25 kN)

2 (2,5 kN)

5 ( 5 kN)

10 ( 10 kN)

25 ( 25 kN)

35 ( 35 kN)

50 ( 50 kN)

100 (100 kN)

150 (150 kN)

250 (250 kN)

350 (350 kN)

500 (500 kN)

650 (650 kN)

750 (750 kN)

1000 (1000 kN)

including the attachments described in the ZIMM engineering catalogue valid at the time of delivery

conform with the following essential requirements of the **Machinery Directive 2006/42/EC**:  
 Annex I, Article 1.3.3, 1.1.5, 1.3.4 and 4.1.2.3

In addition we declare that the relevant technical documentation for this partly completed machinery was prepared in accordance with Annex VII, part B, and undertake to transmit these to the market oversight authorities upon request.

Authorised representative for the compilation of the relevant technical documentation: Mr. Gebhard Stadelmann, AT-6890 Lustenau, Millennium Park 3

**Putting the partly completed machinery into service is prohibited until the partly completed machinery has been incorporated into final machinery which conforms to the provisions of the EC Machinery Directive and there is an EC Declaration of Conformity in accordance with Annex II A.**

**Enclosure: current assembly instructions**

ZIMM Maschinenelemente GmbH & Co KG  
 Millennium Park 3  
 AT-6890 Lustenau, 17th October 2012

Gunther Zimmermann, CEO



Declaration\_of\_incorporation-Screw\_jacks\_10-2012\_EN





**ZIMM**<sup>®</sup> Austria  
Screw Jack Systems

---

ZIMM Maschinenelemente GmbH + Co KG  
Millennium Park 3  
6890 Lustenau / Austria

Phone: 0043 (0) 5577 806-0  
Fax: 0043 (0) 5577 806-8

info@zimm.at  
www.zimm.eu