

DIEQUA
Corporation

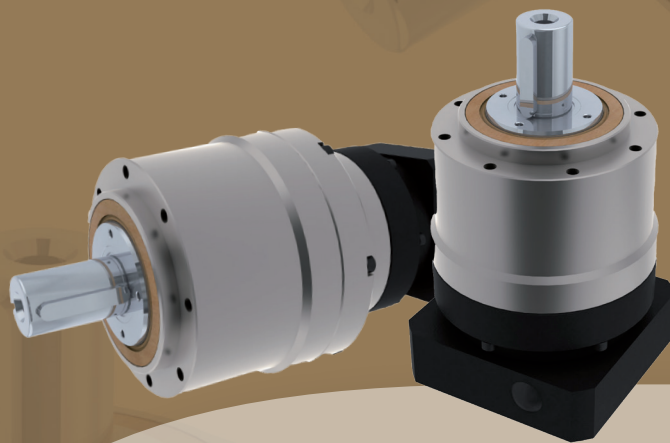

Superior Torque

Superior OHL

Performance Interchange

PHCH SERIES

Servo Gearhead for Packaging Equipment OEM

PHCH SERIES

With our PHCH Series gearheads you don't have to compromise. Experience the power of superior torque and superior over hung load capabilities, all in one gearbox.

Features:

- Perfect stiffness even under the highest bearing loads
- Radial load capacity from 3600N up to 11380N
- High output torque with particularly low-noise drive
- Service-life lubricant for maintenance-free operation
- IP65 sealing



Feature	German Competitor	Asian Competitor	Diequa PHCH Series
Superior OHL	✓	average	✓
Superior Torque	average	✓	✓
Performance Interchange?	NO	NO	✓



DieQua's PHCH Series is specifically designed to meet the rigorous demands of packaging equipment applications. It offers an exceptional combination of enhanced torque capacity and output shaft loading, surpassing even the most demanding requirements. You can rely on the PHCH Series to handle high loads without compromising mounting compatibility.

Available Options:

- 4 Sizes, 70, 90, 115, 155 mm
- Wide Range of ratios, 8-single stage, 13-double stage
- Common mounting dimensions, providing drop-in compatibility for easy integration into existing systems
- Off the shelf motor adapter flange for most popular servo motors
- Short lead-times for popular sizes and ratios

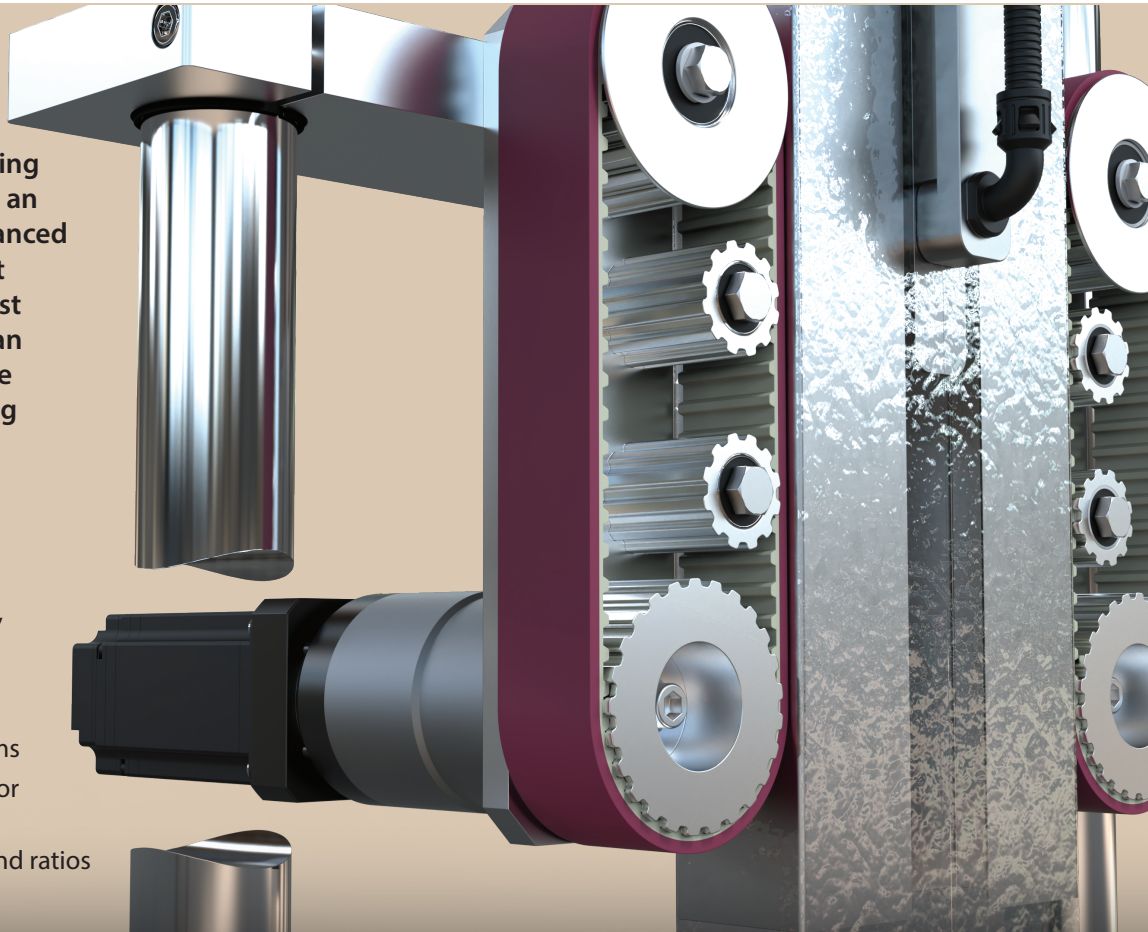

Specifications		Stage	Ratio	PHCH-70	PHCH-90	PHCH-120	PHCH-155
Nominal Output torque T_{2N}	N·m	1	3	53	145	290	520
			4	55	150	300	550
			5	54	140	330	600
			6	46	135	310	560
			7	44	125	300	230
			8	41	110	260	480
			9	37	95	230	130
			10	37	95	230	430
		Stage	Ratio	PHCH-70/PHCH-70T	PHCH-90/PHCH-90T	PHCH-120/PACK-120T	PHCH-155/PHCH-155T
		2	15	53	145	290	520
			20	55	150	300	550
			25	54	140	330	600
			30	54	140	330	600
			35	54	140	330	600
			40	54	140	330	600
			45	54	140	330	600
			50	54	140	330	600
			60	46	135	310	560
			70	44	125	300	530
80	41		110	260	480		
90	37	95	230	430			
100	37	95	230	430			
Max. Output Torque T_{2B}	N·m	60% of Emergency Stop Torque					
Emergency Stop Torque T_{2NOT}	N·m	3.0 Times of Nominal Output Torque					
Nominal Input Speed n_{1N}	rpm	1,2	3-100	4000	4000	3500	3000
Max. Input Speed n_{1max}	rpm	1,2	3-100	8000	8000	6000	5000
Micro Backlash P0	arcmin	1	3-10	≦ 4	≦ 4	≦ 3	≦ 3
		2	12-100	≦ 6	≦ 6	≦ 5	≦ 5
Precision Backlash P1	arcmin	1	3-10	≦ 6	≦ 6	≦ 5	≦ 5
		2	12-100	≦ 8	≦ 8	≦ 7	≦ 7
Standard Backlash P2	arcmin	1	3-10	≦ 8	≦ 8	≦ 7	≦ 7
		2	12-100	≦ 10	≦ 10	≦ 9	≦ 9
Torsional Rigidity	N·m / arcmin	1,2	3-100	7	14	25	50
Max. Radial Load F_{2B}^1	N	1,2	3-100	3600	5800	8410	11380
Max. Axial Load F_{2aB}^1	N	1,2	3-100	2500	4200	5200	8830
Operating Temp.	°C	-10°C ~ +90°C					
Service Life	hr	30,000 (15,000 Continuous Operation)					
Efficiency	%	1	3-10	≧ 97%			
		2	12-100	≧ 94%			
Weight	kg	1	3-10	1.8	3.6	8.0	16.5
		2	12-100	2.4/2.0	5.7/4.0	9.7	19.4
Mounting Position	-	1,2	3-100	Any Direction			
Noise Level ²	dB(A)/1m	1,2	3-100	58	60	63	65
Protection Class	-	1,2	3-100	IP65			
Lubrication	-	1,2	3-100	Synthetic Lubricant			

Stage	Ratio	unit	PHCH-70	PHCH-90	PHCH-120	PHCH-155
1	3	kg·cm ²	0.23	0.65	2.35	10.00
	4		0.18	0.14	1.66	7.17
	5		0.17	0.14	1.50	6.52
	6/7/8		0.97	0.60	1.45	6.17
	9/10		0.67	0.58	1.41	6.10
Stage	Ratio		PHCH-70(T)	PHCH-90(T)	PHCH-120T	PHCH-155T
2	15/20/25		0.17 (0.02)	0.65 (0.17)	0.65	1.50
	30/35/40		0.14 (0.02)	0.60 (0.14)	0.60	1.45
	45/50/60/70/80/90/100		0.14 (0.02)	0.58 (0.14)	0.58	1.41

1. Applied to the output shaft center at 100 rpm.

2. Environment noise level 30 dB; distance 1m; measured under free loading with input speed 3000 rpm; ratio = 10 (1-stage) or ratio = 100 (2-stage).

Please note that the figures and specifications mentioned above are subject to change without prior notice. Additionally, it is important to be aware that products damaged due to factors beyond our control, including human error, natural disasters, or similar events, may not be covered under warranty. For more detailed and specific warranty information, please contact DieQua.

ABOUT DIEQUA

Founded in 1980 by Dietmar Quaas, and now owned by his sons, DieQua Corporation has expanded from a single product line to become a leading manufacturer and supplier of an extensive line of high-quality power transmission and precision motion control products, including gearboxes, servo gearheads, screw jack systems, speed reducers, cycloidal reducers, and connecting components. The company also offers custom product modifications and complete design solutions for virtually any application. DieQua Corporation serves a wide range

of industries, including medical and health care, marine engineering, renewable energy, mining, transportation, steel, forestry and lumber, water and wastewater, automotive, and factory automation, to name a few.

An experienced and knowledgeable technical sales, customer service, and engineering support staff, as well as local distributors, ensure that DieQua customers in North America, Mexico and South America select the optimum components, systems, and best design solutions for their specific requirements.

The DieQua family of products



Spiral Bevel Gearboxes



Servo Gearheads



Cycloidal Reducers & Positioners



Screw Jack Systems



Helical Speed Reducers

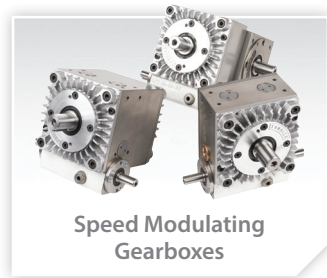

Speed Modulating Gearboxes



Zero Backlash Couplings and Line Shafts

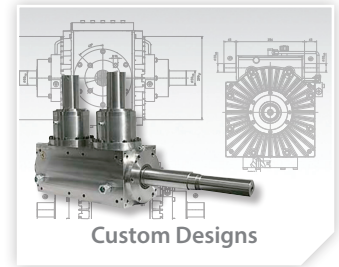

Custom Designs

The DieQua Advantage

Engineering Support

DieQua Corporation has several decades of combined experience specifying power transmission and motion control components. This assures proper selection of components and systems to suit your unique requirements.

Warehousing

We pride ourselves for our extensive in-stock inventory. For fast product turnaround, DieQua Corporation stocks many components of various ratios and sizes, ready to ship fast.

Manufacturing and Assembly

DieQua Corporation now manufactures or assembles most of the products, for on-time delivery of standard orders as well as prototypes. We are ISO 9001 certified and are constantly improving our quality systems to ensure our customers receive the best products.



180 Covington Drive
Bloomington, IL 60108 USA

630.980.1133

www.diequa.com